

---

Xibu

senseFOAM / senseDISINFECT

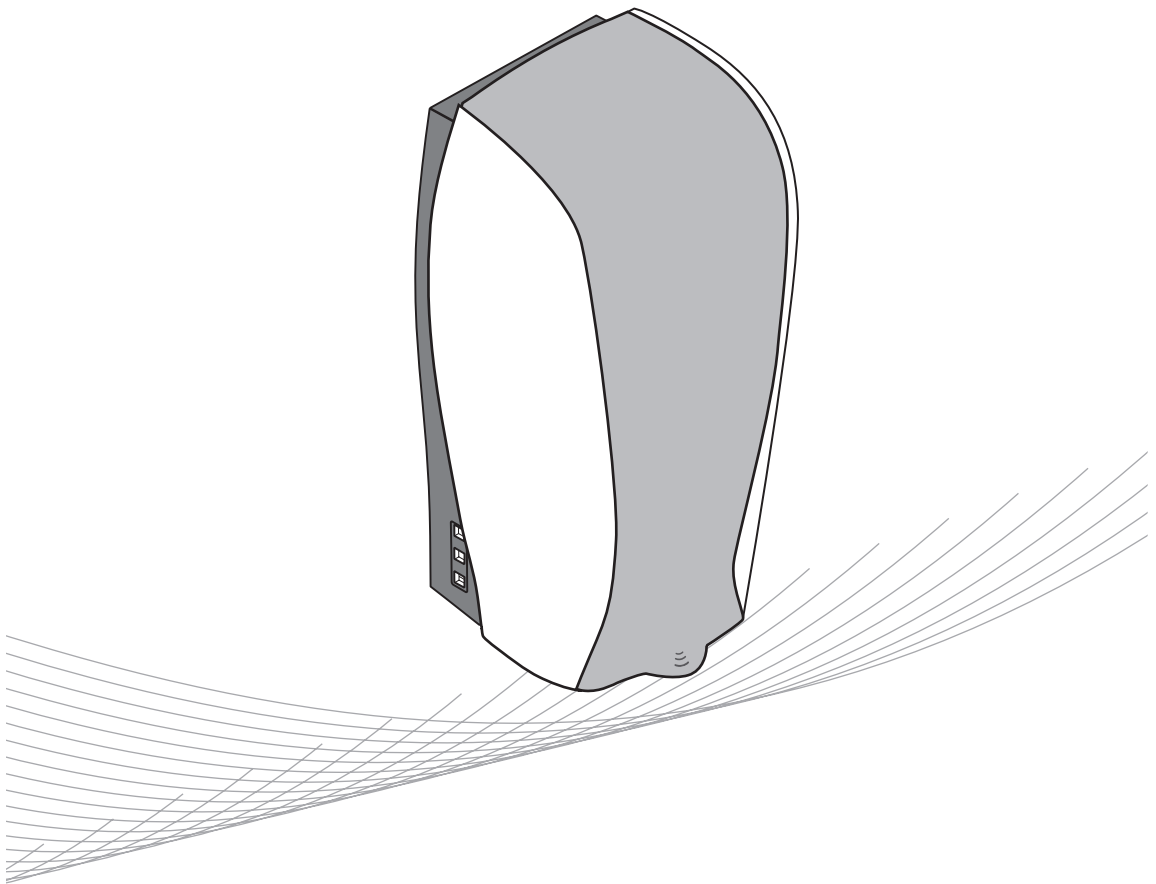

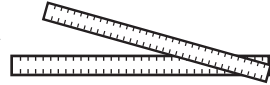
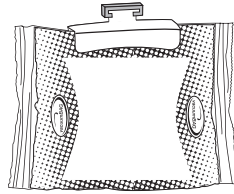
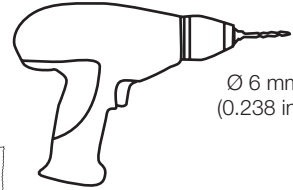
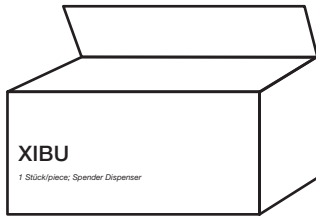

C-Type (baby/LR14/14A)  
ALKALINE

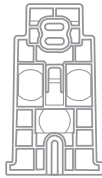

1 x

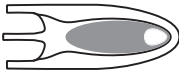

1 x



2 x



2 x



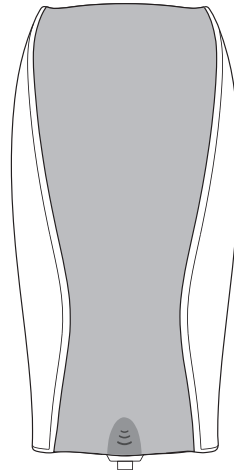

2 x



## FOR THE UNITED STATES ONLY

### General Safety Information

The following symbols and headings are used throughout this manual to indicate possible hazards to persons or equipment. The symbols and headings are shown in order of importance. For efficient and safe operation, be sure to follow the installation and operating instructions provided in this manual. In particular, all safety symbols and notices must be followed.

 <b>WARNING</b>	Indicates a potentially hazardous situation which, if not avoided, could result in serious injury or death.
 <b>CAUTION</b>	Indicates a potentially hazardous situation which, if not avoided, could result in minor personal injury.
<b>NOTICE</b>	This safety warning indicates possible hazards to the product or to other equipment.
<b>IMPORTANT</b>	Vital information or tips for the installer or operator.

### General Safety Instructions

 <b>CAUTION</b>	<p><b>When installing any equipment, ensure that all national and local safety, electrical and plumbing codes are met.</b></p> <p><b>When using electrical appliances, basic safety precautions should always be followed.</b></p> <p><b>Always wear safety goggles to protect your eyes and wear other appropriate safety items for protection to avoid injury when drilling.</b></p>
--	--

### IMPORTANT

- Do not mix old and new batteries. Always remove exhausted batteries and dispose safely.
- Americans with Disabilities Act: Title III of the Americans with Disabilities Act (ADA) governs, in detail, the placement and operation of dispensers. You should ensure that your mounting and use of dispensers complies with that law as well as the regulations issued under that statute. The mounting suggestions in this document may or may not fulfill the obligations of the ADA with respect to your facility.
- For XIBU senseDISINFECT dispensers only: You should ensure that your mounting and use of the XIBU senseDISINFECT dispenser complies with national or local fire code safety regulations.

---

For HAGLEITNER senseMANAGEMENT devices only

NOTE: This equipment has been tested and found to comply with the limits for a Class A digital device, pursuant to part 15 of the FCC Rules. These limits are designed to provide reasonable protection against harmful interference when the equipment is operated in a commercial environment. This equipment generates, uses, and can radiate radio frequency energy and, if not installed and used in accordance with the instruction manual, may cause harmful interference to radio communications. Operation of this equipment in a residential area is likely to cause harmful interference in which case the user will be required to correct the interference at his own expense.

1.

### NOTICE

Do not install the dispenser above a mirrored surface and maintain the minimum installation dimensions in order to prevent unnecessary activation of the dispenser

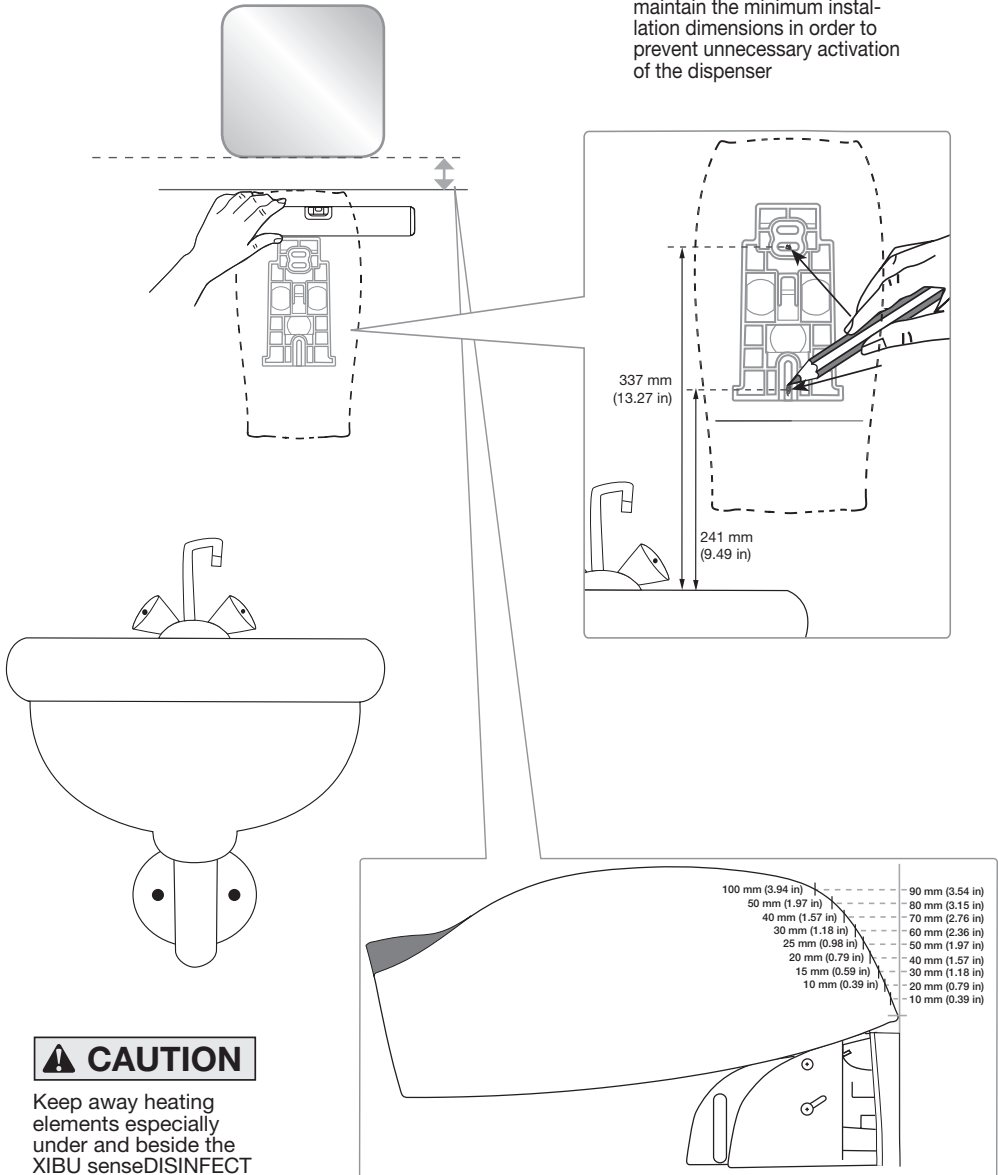

### CAUTION

Keep away heating elements especially under and beside the XIBU senseDISINFECT dispenser. Keep the dispenser away from sources of ignition.

## Option

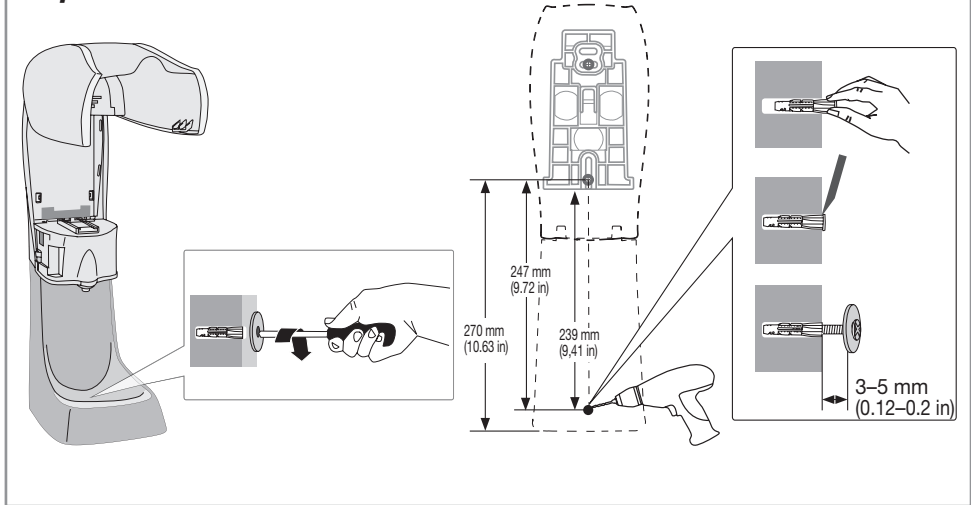

2.

2 x

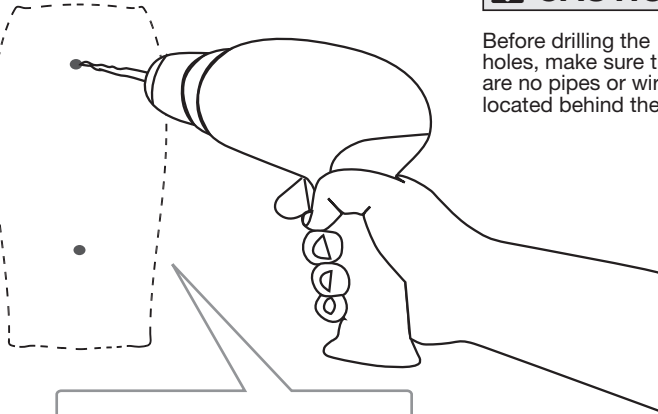

### **CAUTION**

Before drilling the holes, make sure there are no pipes or wires located behind the wall

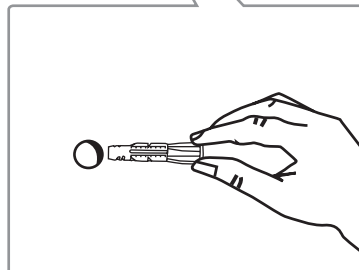

### **NOTICE**

Only mount on flat surfaces

3.

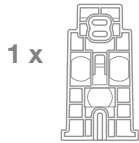

### IMPORTANT

Insert screws and ensure that the dispenser is level before tightening completely

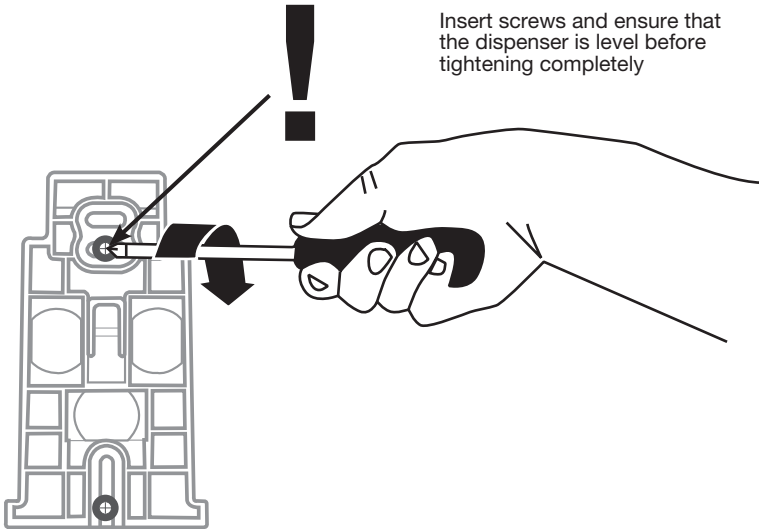

4.

1 x

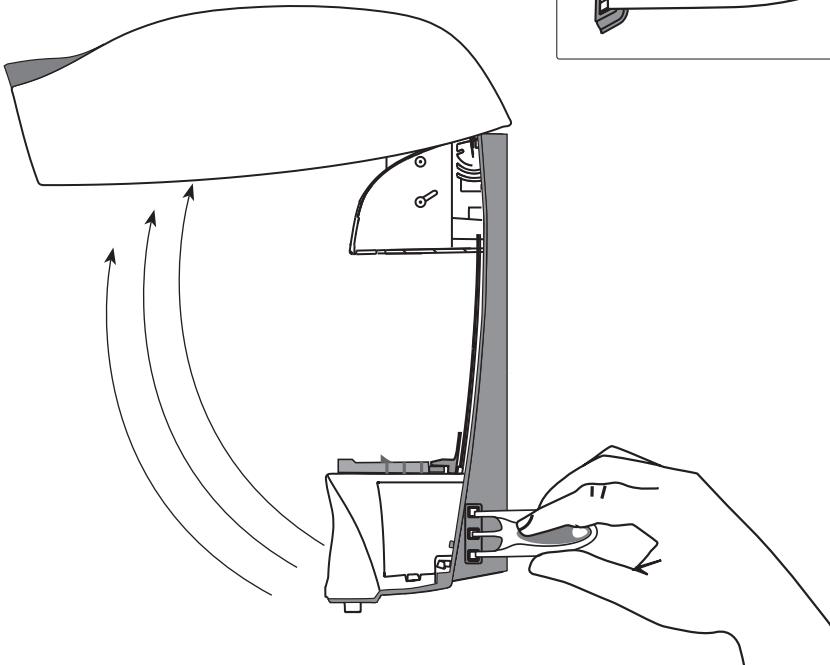
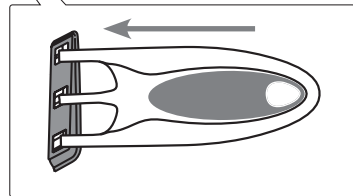
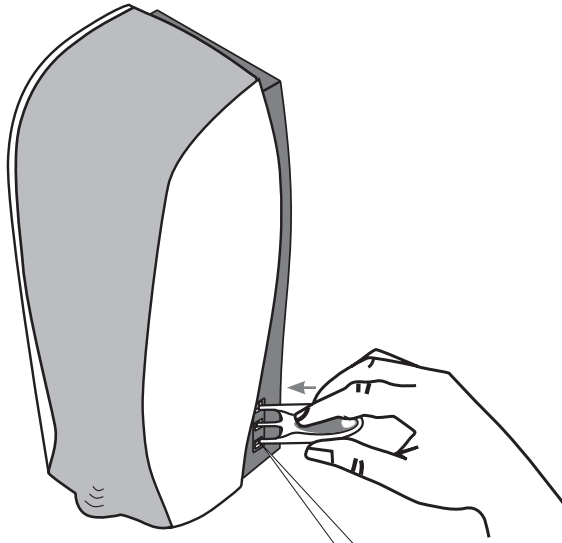
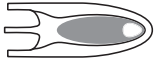

5.

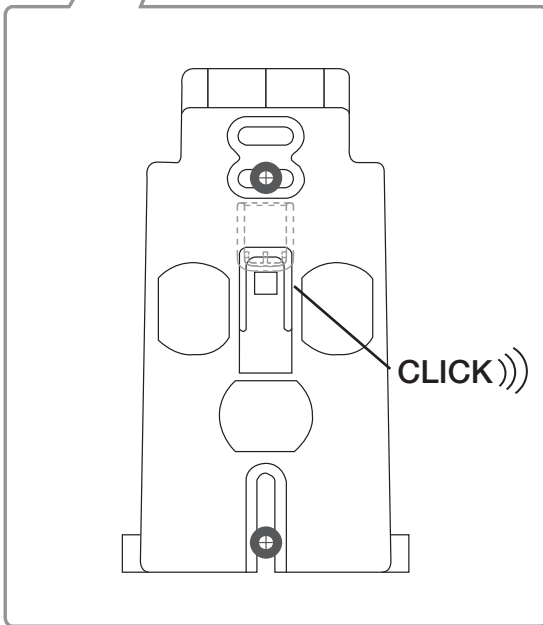
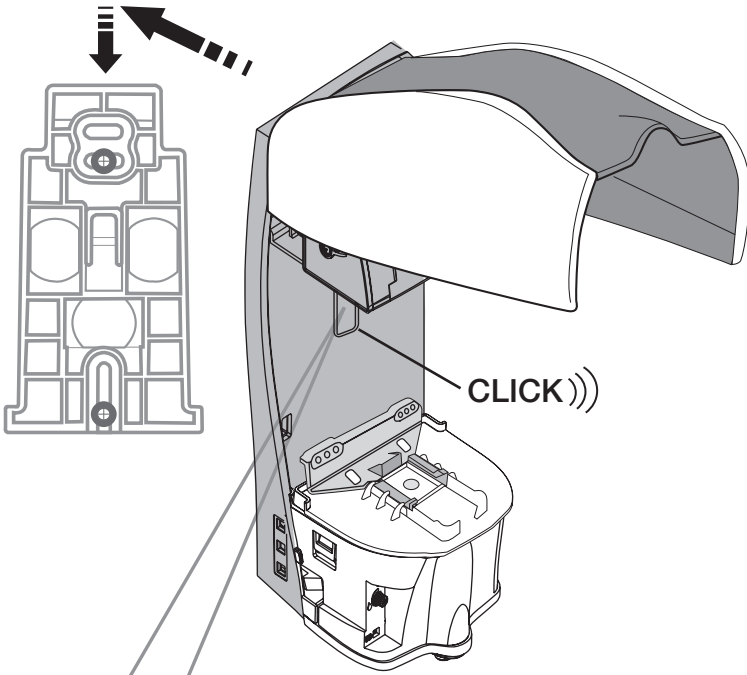



6.

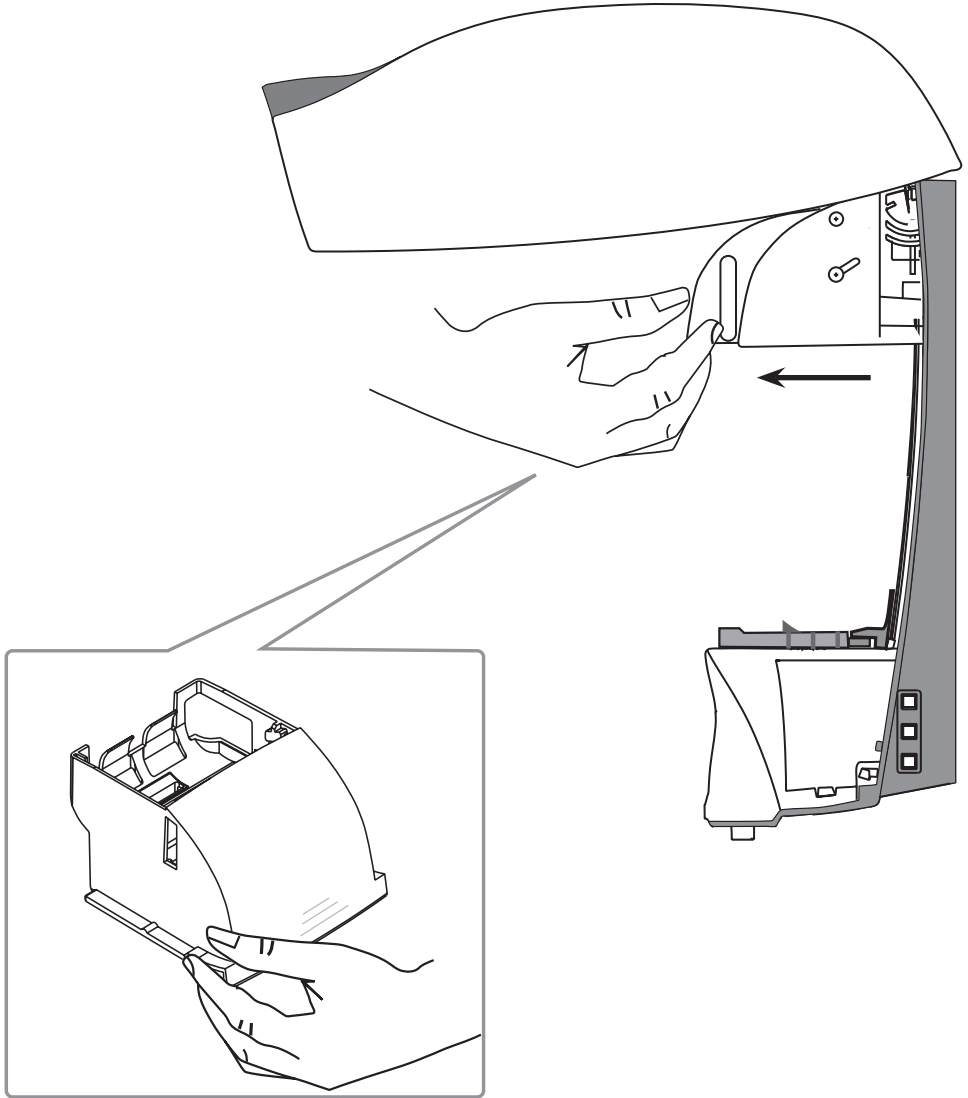

7.

1 x



**CAUTION**

Please verify that the correct product is used

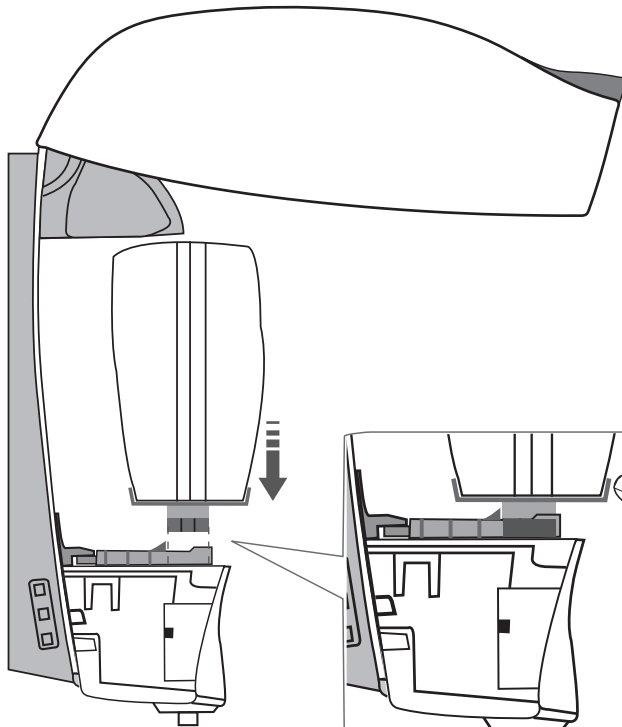
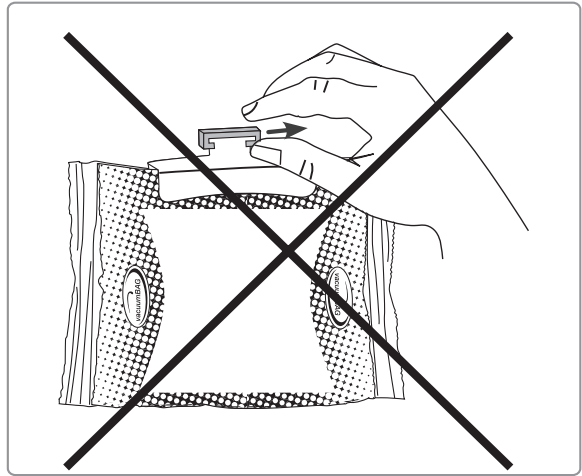

**NOTICE**

Do not remove the cover of the vacuumBAG. The lid is automatically positioned and opened when placed in the dispenser

8.

C-Type (baby/LR14/14A)  
ALKALINE

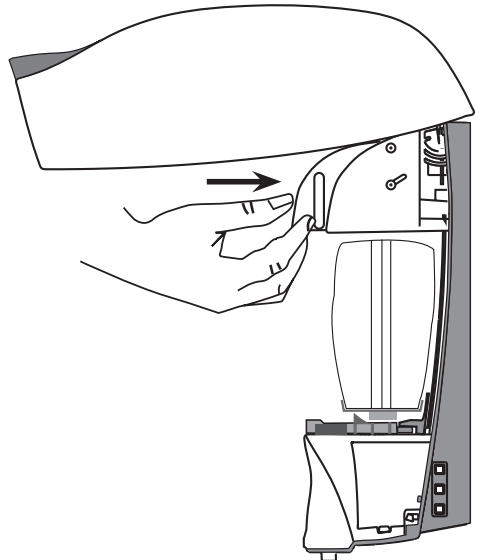
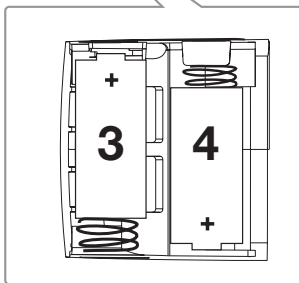
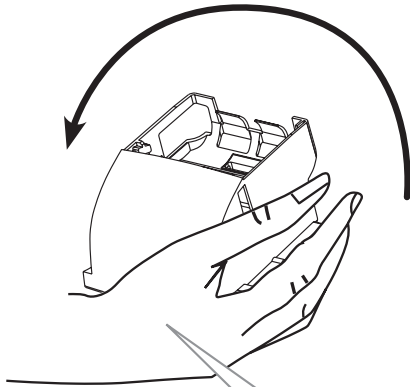
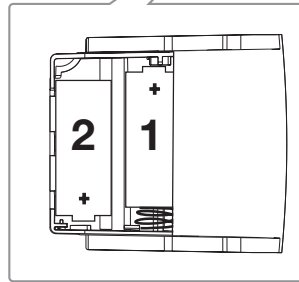
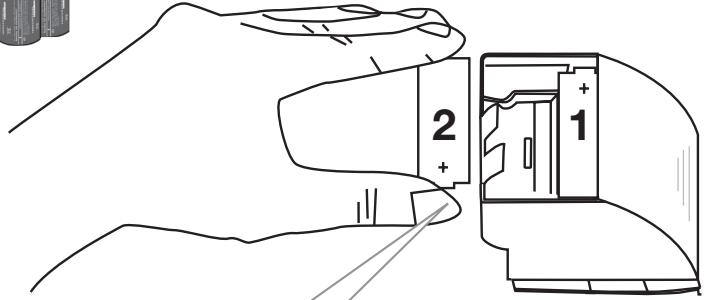

9.

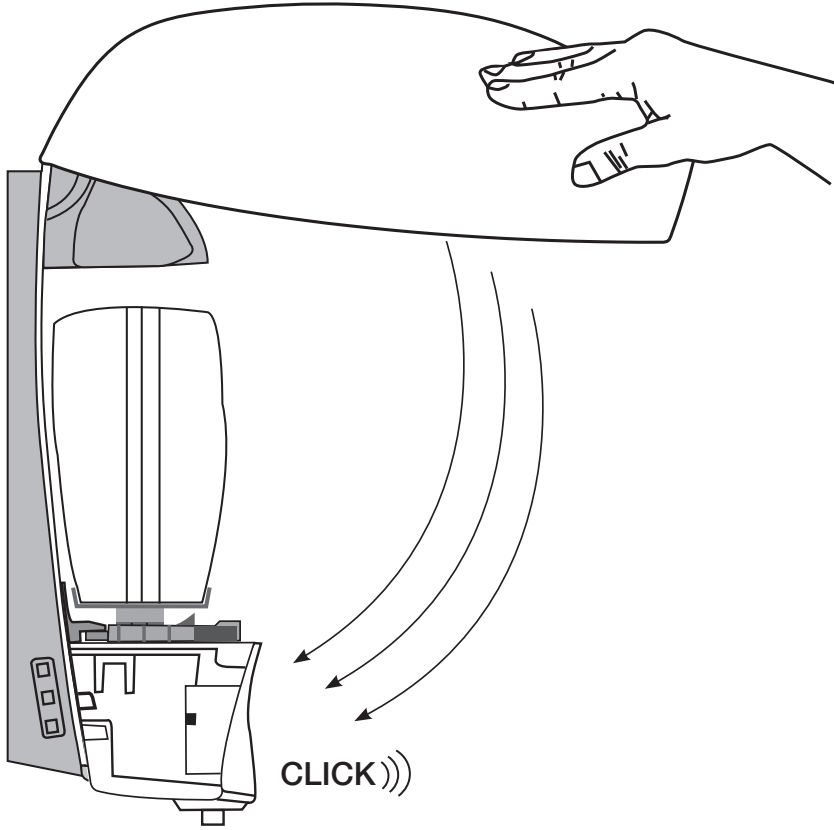

10.

senseFOAM

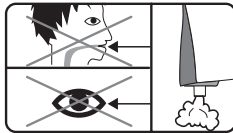
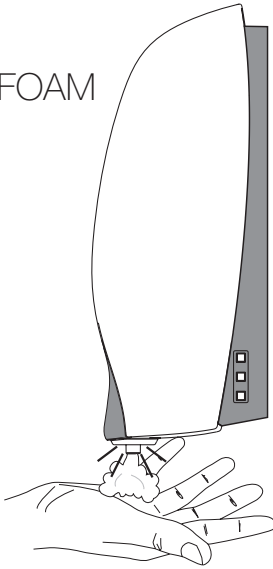

senseDISINFECT

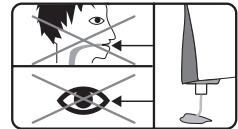
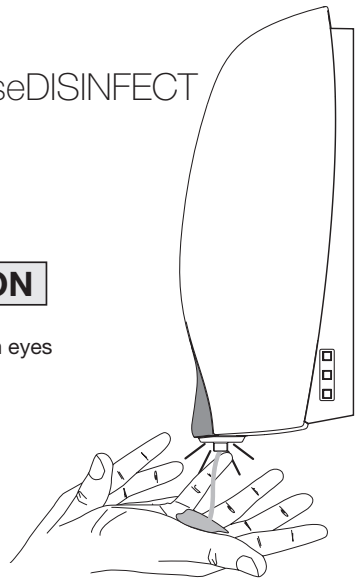

**CAUTION**

Do not swallow  
Avoid contact with eyes

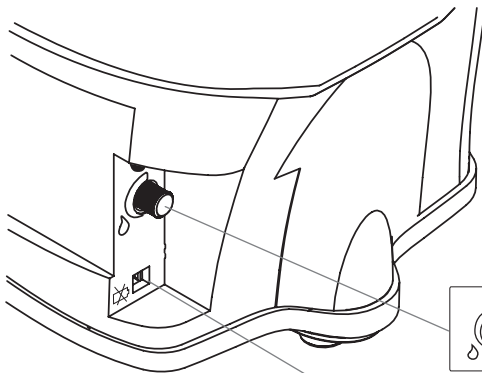



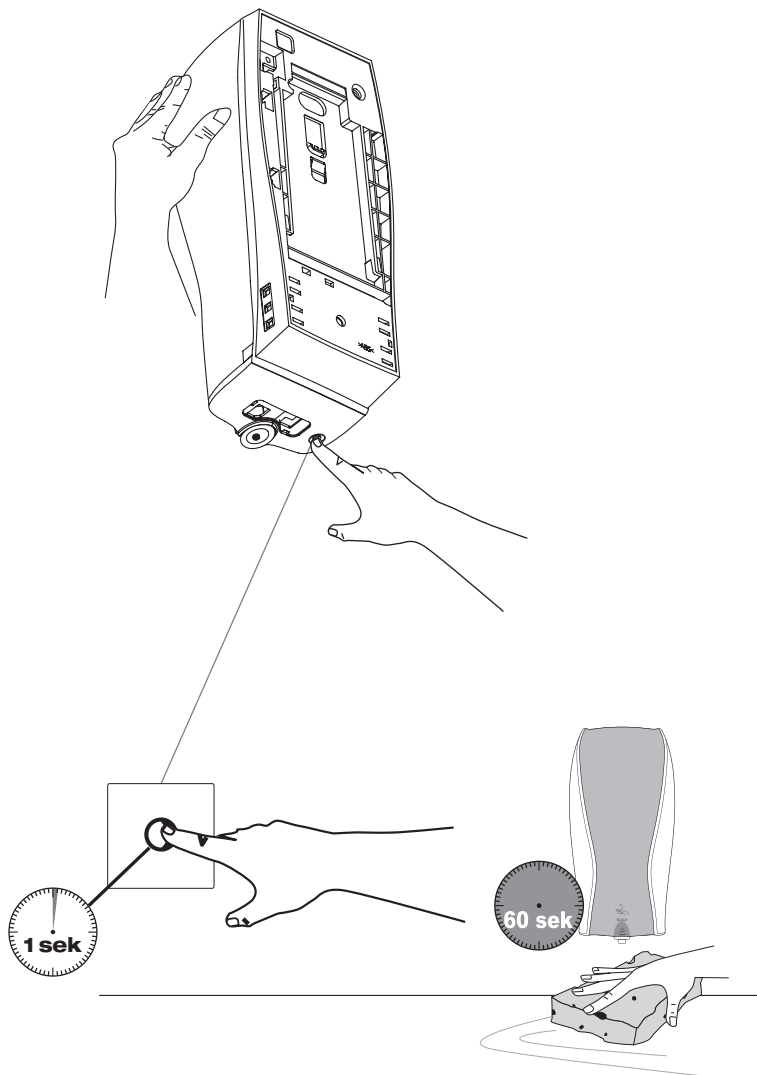

→ (8.)

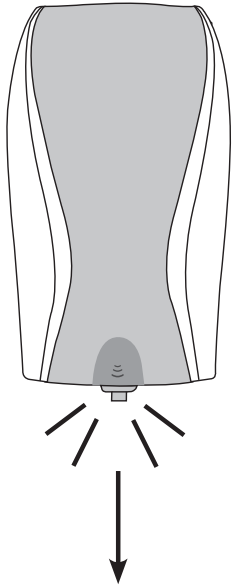

## IMPORTANT

Press the cleaning button for 1 second before cleaning. The dispenser will not dispense for a period of 60 seconds



green = ok  
green+red = change  (8., 9.) /  (7., 9.)  
red =  empty

# EC-DECLARATION of CONFORMITY

The distributor:

Company  
Hagleitner Hygiene International GmbH  
Lunastraße 5  
5700 Zell am See

declares under our sole responsibility that the entire system

## XIBU sense FOAM / DISINFECT

<b>Type: Dispenser</b>	<b>Mach. Nr.: 035 / P0041</b>	<b>Year of manufacture: 2018</b>
------------------------	-------------------------------	----------------------------------

Corresponds to the following regulations and standards:

### - European Directives regulations:

2006/42/EC	Machinery directive
2011/65/EU	Restriction of certain hazardous substances in electronic equipment
2014/30/EU	Electromagnetic Compatibility (EMC) directive
2014/35/EU	Low Voltage Directive

### - Harmonised standards:

EN ISO 12000	Safety of machinery
EN IEC 60947	Low-voltage switchgear and controlgear
EN 60204-1	Electric equipment of machines, gen. demands
EN 61000-6-2	Electromagnetic compatibility – immunity
EN 61000-6-3	Electromagnetic compatibility – emission
EN 61000-4-2	Electrostatic discharge immunity
EN 61000-4-8	Power frequency magnetic field immunity

The technical documentation is complete. The associated instruction manuals in the languages German and English are enclosed.

Zell am See, am 20.12.2017



Hans Georg Hagleitner  
Chief Executive Officer  
Hagleitner Hygiene International GmbH